

ALARM ANNUNCIATORS WITH DISPLAY

ADDA 4/8/12 ALARM ANNUNCIATORS

ALARM ANNUNCIATORS FOR HIGH VOLTAGE PANELS

Developed by MIMIC COMPONENTS, this alarm annunciator has been designed specifically for use with **High Voltage Panels** which normally operate with a battery supplied control voltage of 110V DC.

The main distinguishing feature is ADDA's **extremely low current consumption**, hence battery power is conserved and this in turn enables the unit to operate directly off 110V DC with very little heat.

ADDA can be supplied in modular compact modules (96x96mm) either 4 ways or 8 ways, which can be added together to make up any reasonable quantity of alarm points.

The standard unit is made for 110V DC, however 24V and 48V DC units are also available.

The system operates on a normally open contact which closes on fault. On receipt of a closing contact, the hooter sounds and the appropriate LED flashes. On acceptance, the hooter silences and the LED goes steady. In the Auto-Reset model the LED goes out when the fault clears. In the Manual Reset model, the LED stays on until the Reset button is pressed. In either case, fleeting alarms are latched until accepted.

Subsequent alarms are recognized, i.e. If there are alarms on the system, a new alarm will initiate a flashing LED and sound the hooter without affecting existing alarms.

The aim of the ADDA is to plug the gap in the market between the imported flag relays (which are expensive), and the industrial alarm annunciators. It also provides a locally manufactured unit designed specifically for reliable and immune operation in H.T. switch gear panels.

Using conventional Industrial Alarm Annunciators for 110V DC is not satisfactory as they usually operate on 24V DC and thus require an expensive and often unreliable DC to DC converter.

SUFFIX CODE: **A4P** (4-way) **M** **X** **RT** **C** **110D**

A8P (8-way)
A12P (12-way)

CODE	CONTROL(4 & 12 WAY ONLY)	CODE	OPERATING VOLTAGE
C	Pushbuttons & buzzers	12D	12 VOLTS DC
	No control	24D	24 VOLTS DC
		32D	32 VOLTS DC
		48D	48 VOLTS DC
		110D	110 VOLTS DC

CODE	FUNCTION	CODE	OUTPUT	CODE	TERMINAL TYPE
M	MANUAL (Key) Reset	S	Standard Output	RT	Removable Terminals with screw fixing
A	Automatic Reset	X	Extended Output		Fixed Terminals

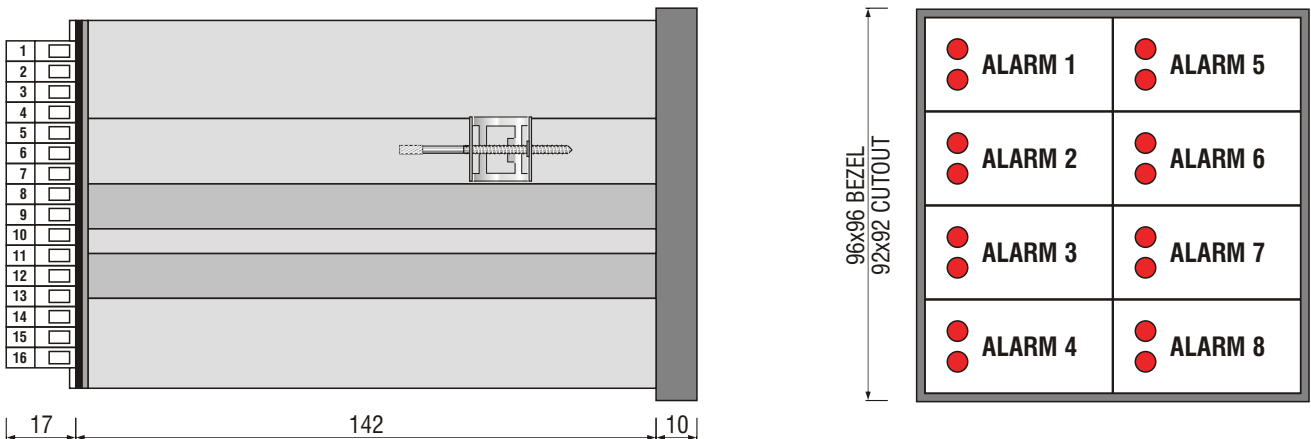

NEW VELVAGRAPH FACE: MATT BLACK or colour coordinated to your panel

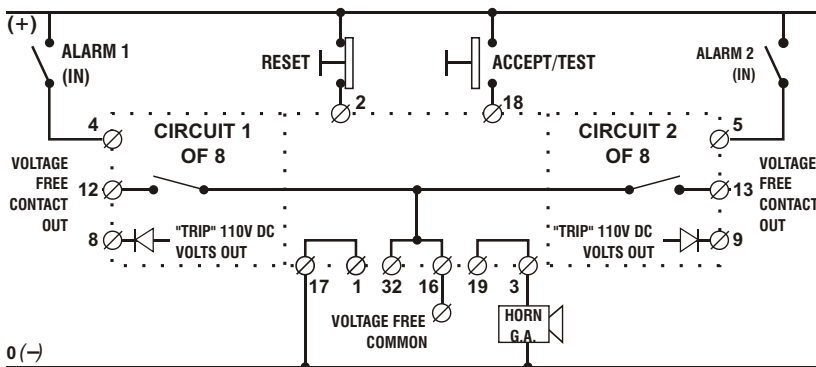

ADDA 8 - TYPICAL CONNECTION
(ABOVE DIAG. IS FOR 2 OUT OF 8 ALARMS)

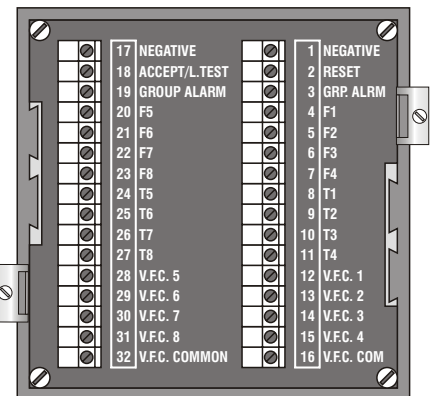

CONNECTION DIAGRAMS

ADDA 4 "S" & "X" (STANDARD & EXTENDED VERSIONS)

AVAILABLE IN MANUAL OR AUTO-RESET MODELS, & FOR OPERATION ON 12, 24, 32, 48, & 110V DC.
This page must be read in conjunction with page 6.6

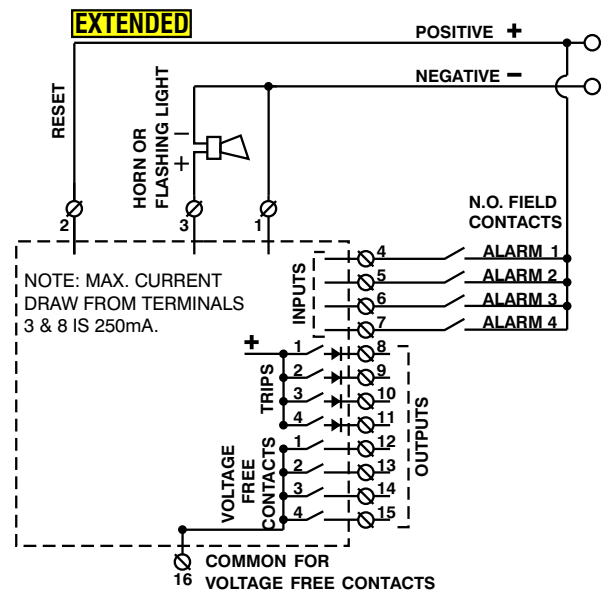
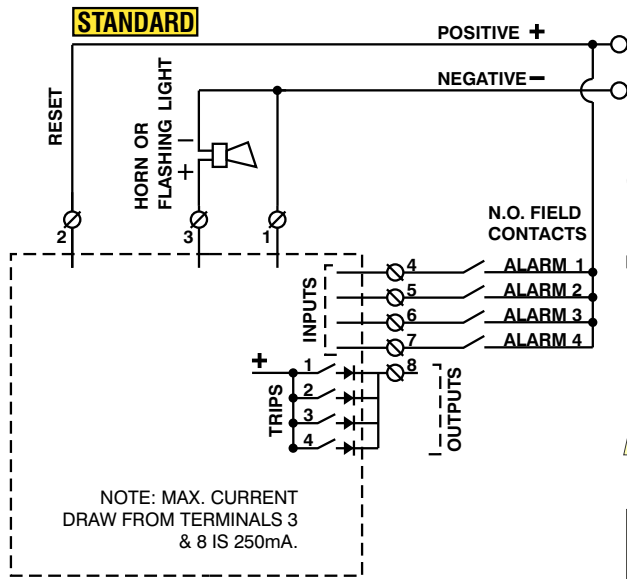

STANDARD
EXTENDED

THE EXTENDED VERSION OFFERS:

- Individual trips per alarm circuit.
- One N/O clean contact per alarm (12, 13, 14 & 15). This closes on receipt of fault and opens when fault is reset, these have common 16.

REAR

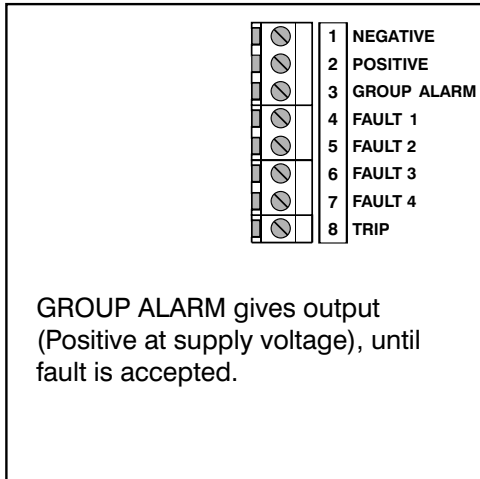

REAR

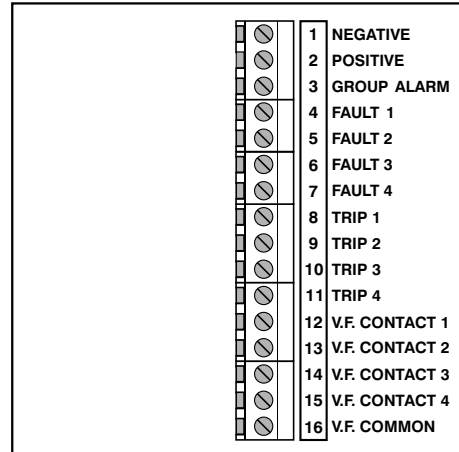

DISPLAY OPTIONS

ADDA4 WITH CONTROL (MANUAL RESET)

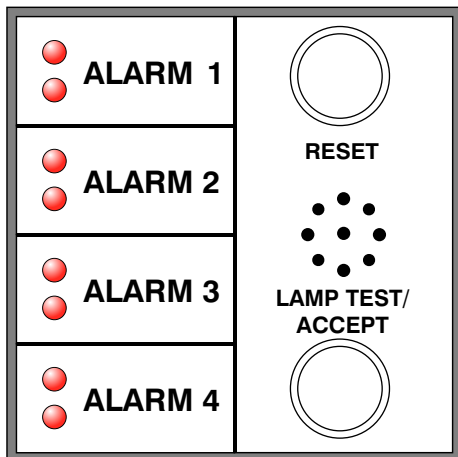

In the AUTO-RESET VERSION there is no reset button & Positive is connected directly to terminal 2.

NOTE:

Engraving of Front Panel is free if details are supplied on order, otherwise engraving is extra.

ADDA4 WITH NO CONTROL

(more space for alarm descriptions)

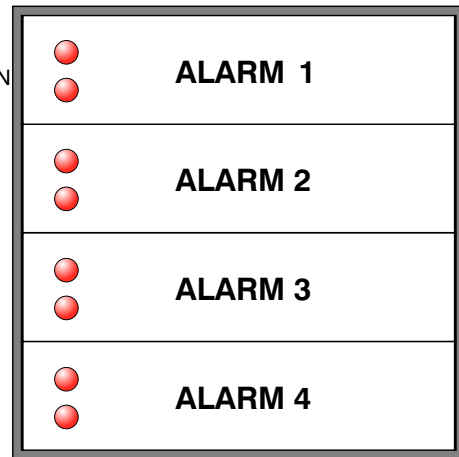

ADDA 8/12 "S" & "X" (Standard & Extended Version)

AVAILABLE IN MANUAL OR AUTO-RESET MODELS, & FOR OPERATION ON 12, 24, 32, 48, & 110V DC.

THIS UNIT IS ONLY SUITABLE FOR NORMALLY OPEN FIELD CONTACTS THAT CLOSE ON FAULT.

This page must be read in conjunction with page: 6.6

Max. current draw from terminals 3, 8 to 11, 16, 19, 24 to 27 is 250mA. **Group Alarm** is positive out at supply voltage 250mA, for Horn etc...

In the **Auto-Reset** model there is no Reset button & positive is connected directly to terminal 2.

STANDARD

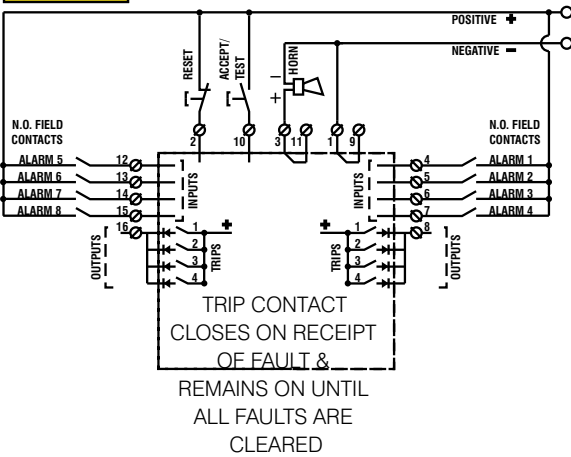

REAR

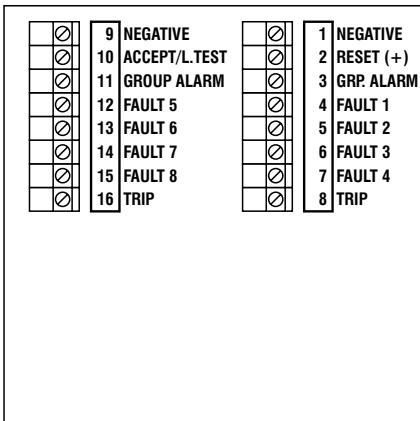

EXTENDED

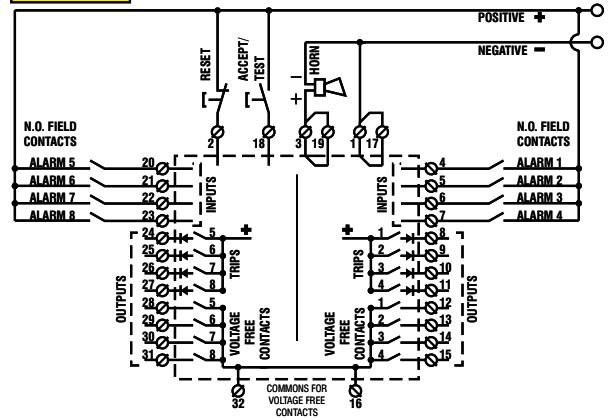

THE EXTENDED VERSION OFFERS:

Individual trips per alarm circuit.

One N/O clean contact per alarm (12, 13, 14, 15, 28, 29, 30, 31).

This closes on receipt of fault and opens when the fault is reset.

These have commons 32 and 16 which can be separated per alarm group of four.

REAR

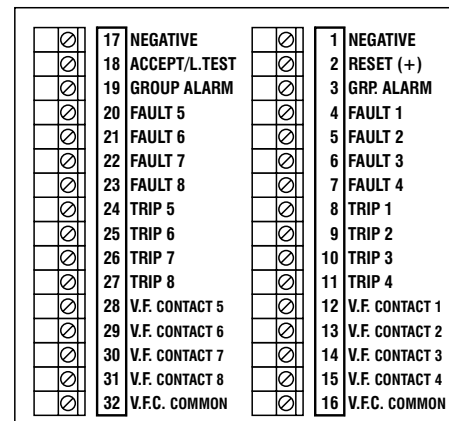

S
E
T
A
N
D
A
R
D

X
E
T
E
N
D
E
D

ADDA 8

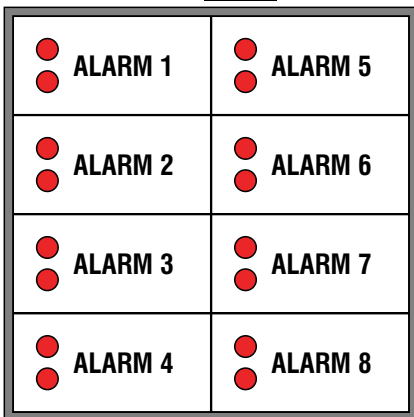

ADDA 12

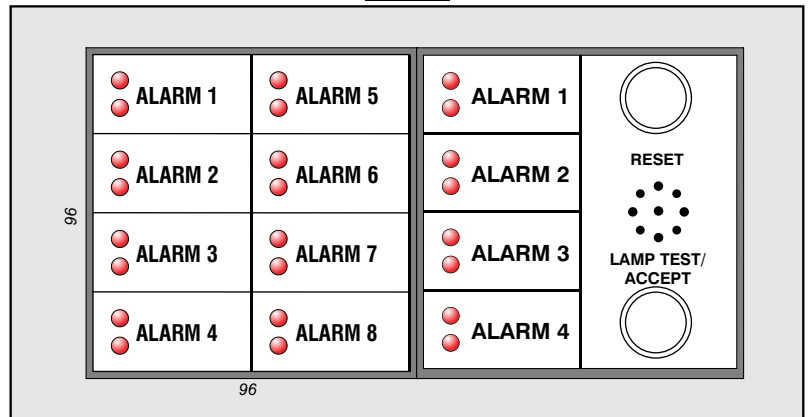

FRONT BEZEL (96x192mm)
PANEL CUT-OUT (92x188mm)

NOTE: Engraving of Front Panel is free if details are supplied on order, otherwise engraving is extra.

RESET DIAGRAMS

ADDA 4/8/12

MANUAL RESET

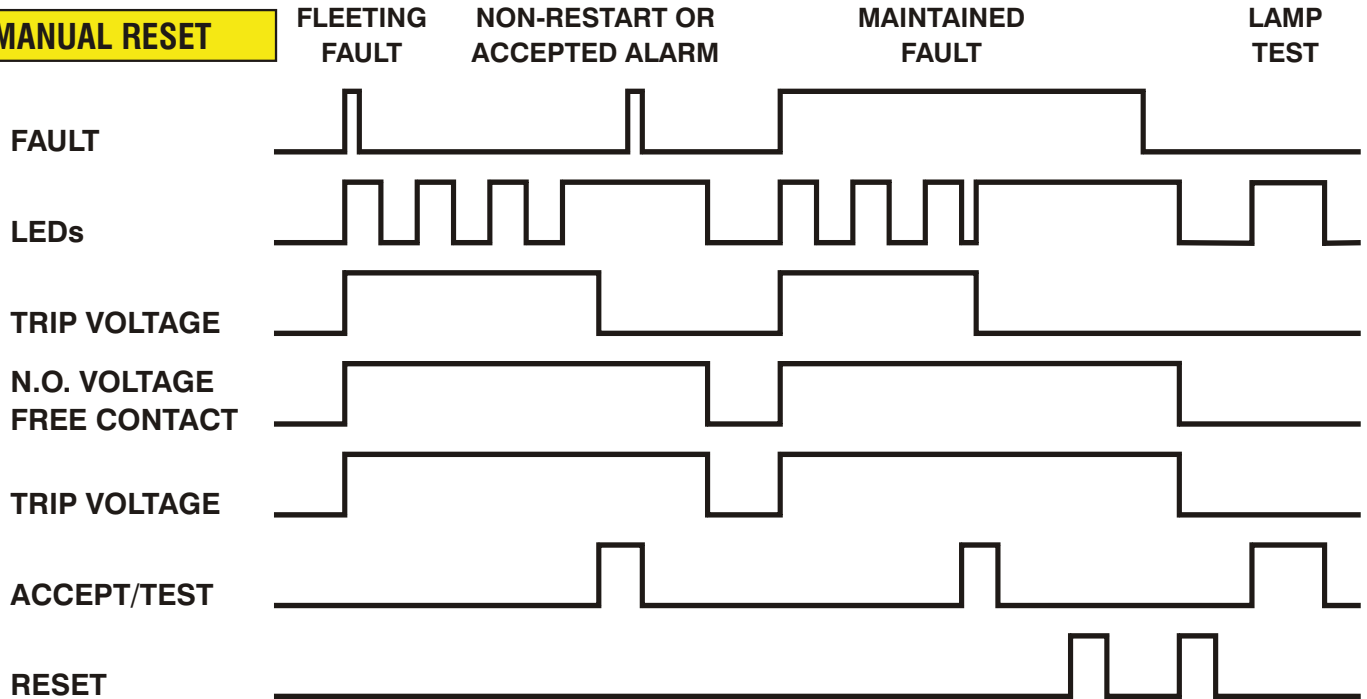

NOTE: MAXIMUM CURRENT DRAW FROM TRIP OUTPUTS IS 200mA.
 INDIVIDUAL TRIPS MAY BE GROUPED (WIRED OR 'ED).
 I.E. FOR DELAYED AND NON-DELAYED TRIPS THEY CAN BE GROUPED &
 THE DELAYED GROUP FED TO AN EXTERNAL TIME RELAY.

AUTOMATIC RESET

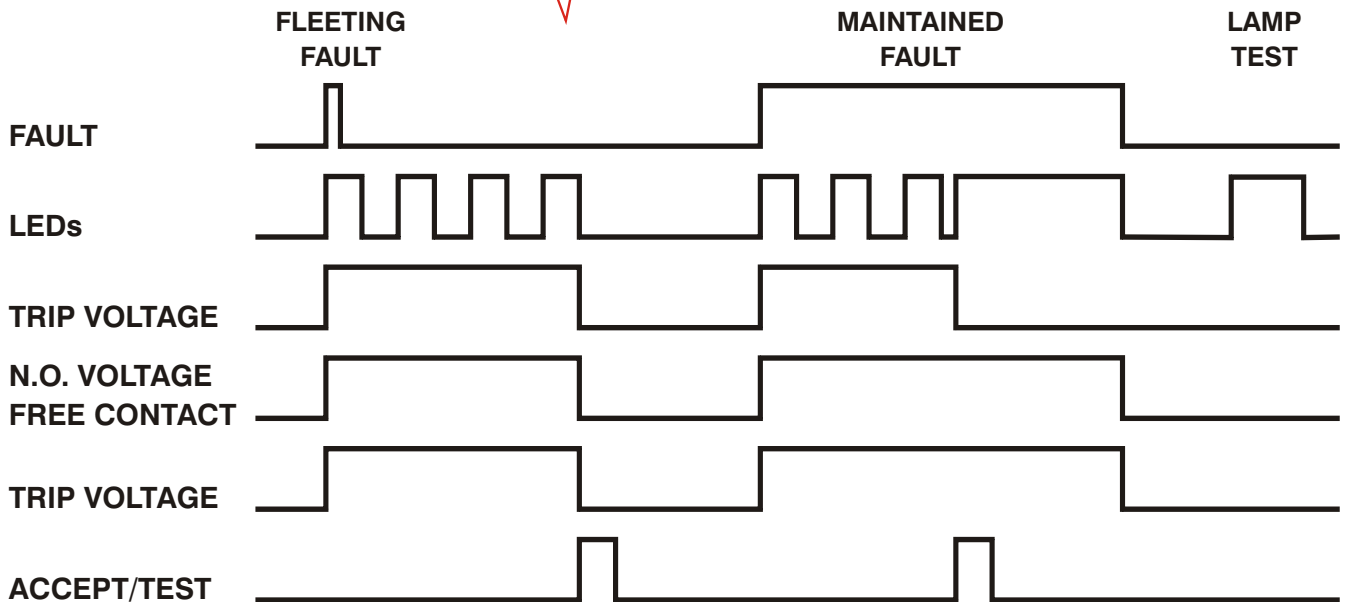

NOTE : MAXIMUM CURRENT DRAW FROM TRIP OUTPUTS IS 200mA.
 INDIVIDUAL TRIPS MAY BE GROUPED (WIRED OR 'ED).
 I.E. FOR DELAYED AND NON-DELAYED TRIPS THEY CAN BE GROUPED &
 THE DELAYED GROUP FED TO AN EXTERNAL TIME RELAY.
 RESET INPUT BECOMES POSITIVE (+) INPUT.