

# ADDA APM4

## 4 WAY MODULAR PANEL MOUNT ALARM ANNUNCIATOR SYSTEM



**ALARM UNIT**  
(bezel size 48x144mm)

**CONTROL UNIT**  
(bezel size 48x144mm)

# ADDA APM4 ALARM ANNUNCIATOR SPECIFICATION & INSTALLATION MANUAL

## General description:

The Adda APM4 micro controller based alarm annunciator system was designed for use as an industrial panel mount alarm system. This modular system comprises of 4 way panel mount alarm modules which wire directly to the field and a control unit which houses the pushbutton, inputs and power supply inputs as well as potential free contacts for the horn and trip functions. The alarm units consist of 4way alarm modules with field inputs and integrated displays. One control unit can drive up to 16 slave units, thus expanding the alarm unit to a 64 way alarm. With custom ribbon cables this limit can be extended to above 150 alarms.

## Main Functions:

Each input provides for normally open or normally closed alarms via Dip-switch.

Each unit provides for normally on (inverse) led drive e.g. For use as Mains On alarms etc. (Jumper setting on rear of unit)

All slave modules have dip-switch settings for the following control options: First on fast flash / Manual or Auto reset / Ringback / and input fast or slow response time.

The system is modular expandable - up to 64 slave units.

The units are interconnected via a standard 10-way ribbon system.

The master unit has pushbutton facilities for Lamp Test / Accept / Reset inputs as well as potential free relay contacts for Horn and Trip outputs.

Optional opto-coupled inputs with additional external PSU.

## Legend manufacturing and insertion instructions:

A Sheet of Laser printable and a sheet of ink-jet printable paper is supplied with each unit.

A Template for Microsoft Word is also supplied to simplify the setup for printing.

## To Print the legend:

Insert disk with template in disk drive. A copy of this template is also available as a download on our Website at: <http://www.mimic.co.za>

Open template with Microsoft Word.

Type text required into each alarm window. Bitmaps for pictures can also be inserted. (using insert picture macro)

Once you are happy with all text and legends, print a copy on standard paper for final checking.

If required save a copy of insert for future use. Use save as command.

Insert special transparent paper and print final copy.

Cut on outline of border.

Remove bezel from front panel as well as clear plastic lens.

Insert legend and replace lens and bezel.

## Led Backlight colours

The colour of the back lit display can be altered by replacing the individual Led Backlight PCB's behind the front panel diffuser.

First remove the front Black Edge Bezel, then remove the Clear Front Panel, the Legend Film, the Opaque Diffuser & the three central Vertical Dividers. The Led PCB'S can easily be removed with your fingers. When replacing the boards with those of the correct desired colour Note that the backlight boards have asymmetrical rows of pins that plug into the sockets inside the annunciator. The unit is then re-assembled in reverse order of Vertical Dividers, Opaque Diffuser, Legend Film, Clear Front panel & Black Edge Bezel.

The Led Backlight PCB's are available in two types,

1/ Single Colour

Red. Orange, Yellow. Green Blue & White.

2/ Three Colour Switchable

This unit can be switched between the colours Red, Yellow or Green.

## FUNCTIONS DESCRIPTION

### Dip-switch functions:

#### **Normally Open/normally closed:**

Normally open alarm is activated when a positive input is present.

Normally closed: alarm is activated when the positive input is not present.

**First on fast flash:** The first alarm received flashes faster than the alarms that follow. This function works in groups of four for each alarm slave unit.

#### **Auto/manual:**

**Auto:** Momentary (fleeting) alarms, Leds flash . Horn is silenced with Accept pushbutton, lamps go to steady. The alarm auto resets when inputs return to normal state:

**Manual:** Momentary (fleeting) alarms, Leds flash. Horn is silenced with Accept pushbutton, lamps go to steady. The alarms will only reset when the Reset pushbutton is pressed and the inputs have returned to the normal state.

SLAVE DIPSWITCH FUNCTIONS			
No.	FUNCTION	OFF	ON
1	INPUT 1 POLARITY	N.O.	N.C.
2	INPUT 2 POLARITY	N.O.	N.C.
3	INPUT 3 POLARITY	N.O.	N.C.
4	INPUT 4 POLARITY	N.O.	N.C.
5	FIRST ON FAST FLASH	N.A.	Activate
6	AUTO/MANUAL RESET	Manual	Auto
7	RINGBACK	N.A.	Active
8	INPUT RESPONSE TIME	5mS	0.5 Sec.
N.O. = Normally Open			
N.C. = Normally Closed			
N.A. = Not Active			

**Ringback:** The ringback option will sound the horn for one second each time an alarm returns to the normal state. I.e. after Accepting alarms in the Auto reset state or manually resetting alarms.

**Input response time:** This setting allows for each slave unit's input response time to be set. This allows for fast response on required inputs or 1/2 second debounce on noisy input lines.

### Internal functions: (alarm units)

**Led invert function:** This function allows for the inversion of the lamp output for normally on situations. This allows for alarm inputs where the alarm must be activated when the led goes to the off state. E.g. Mains on lamps etc. The lamp will normally be on and when the input is activated the lamp will start flashing, upon acceptance of the alarm the lamp will be cleared. Once the alarm is returned to the normal state and the alarm unit reset the lamp will return to the normally on state. This function can be selected by removing the internal jumpers as indicated in Fig3.

### Control unit functions:

**Horn:** The horn output is activated when a flashing alarm is active. This is silenced when the alarm is accepted. It is also active in the ringback option as described before.

**Trip:** The trip relay is active whenever an alarm is active. This output is only cleared when all alarms are in the normal state.

### Power Supply & Input Voltage Considerations

These ALARM units have the ability for the internal operating voltage to be different from that of the input circuit.

This internal operating voltage is 24V and is fed via the ribbon cable from the Control unit. In systems where the Alarm Field Inputs are direct fed (not opto-coupled isolated) a single power supply of 24VDC can be used for both the internal electronics operation and for the field inputs.

How ever if you refer to Typical Wiring drawings A, B & C it is obvious that when the Link between terminal 7 & 8 is removed and the Field Inputs are Wired as per B or C. Then it is possible to have Alarm units with different Field Voltages in the same system. Please Note that this will involve the negative supply lines being commoned via the ribbon cable.

If the OPTO-COUPLED input cards are used the GALVANIC ISOLATION between the different Voltage Power Supplies can be maintained.

Due to the flexibility of the design it is also possible to mix Opto and Non-Opto Input Cards in the same system, however these differences can only be implemented on a per module basis.

If Alarm Modules are ordered with the optional Follow-Me Relays these are always operated at the same supply voltage as the inputs and are run in parallel with these inputs. In this case the PSU's must be sized to handle the Relay operating currents.

### INPUT FOLLOW-ME RELAY CURRENT BURDEN

OPERATING VOLTAGE	RESISTENCE CURRENT (mA)	EFFECTIVE MAXUIM
12DC	220 OHMS	55mA
24DC	900 OHMS	27mA
32DC	900 OHMS	27mA
48DC	3600 OHMS	14mA
110DC	18600 OHMS	6mA

**For Large System these units can be fitted with sensitive coil relays. Please consult with the factory for additional costs and delivery.**

## ADDA APM4 CONTROL MODULE

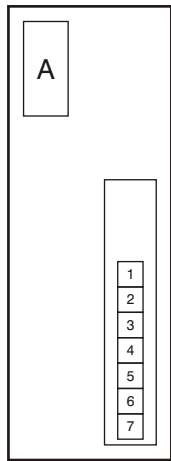

**24V VERSION**

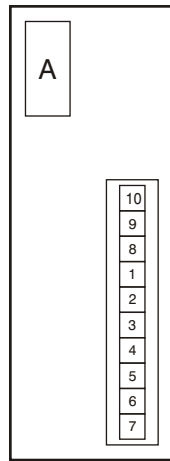

**230V VERSION**

- 1 +24V DC IN
  - 2 0V IN
  - 3 HORN NORMALLY OPEN
  - 4 HORN COMMON
  - 5 TRIP COMMON
  - 6 TRIP NORMALLY CLOSED [N/C]
  - 7 TRIP NORMALLY OPEN [N/O]
- A BUS RIBBON TO ALARM MODULE

- 1 24V DC OUT
- 2 0V DC OUT
- 3 HORN NORMALLY OPEN
- 4 HORN COMMON
- 5 TRIP COMMON
- 6 TRIP NORMALLY CLOSED [N/C]
- 7 TRIP NORMALLY OPEN [N/O]
- 8 EARTH
- 9 LIVE
- 10 NEUTRAL

## ADDA APM4 ALARM MODULE

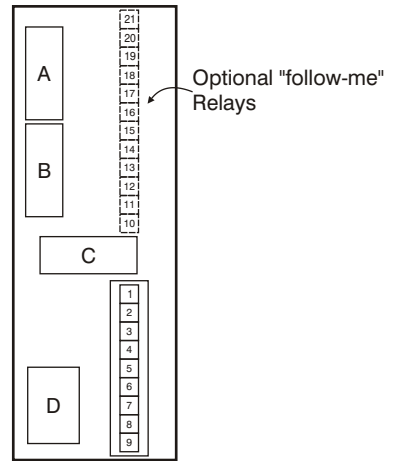

**CONNECTIONS**

- A BUS RIBBON TO NEXT ADJACENT MODULE IN PARALLEL
  - C SLAVE DIP SWITCH FUNCTIONS
  - D LED INVERT FUNCTION
- 1 ALARM 1 INPUT
  - 2 ALARM 2 INPUT
  - 3 ALARM 3 INPUT
  - 4 ALARM 4 INPUT
  - 5 ALARM COMMON OUTPUT
  - 6 ALARM COMMON OUTPUT
  - 7 INTERNAL 24 VOLTS
  - 8 ALARM COM VOLTAGE INPUT
  - 9 COMMON (-VE)

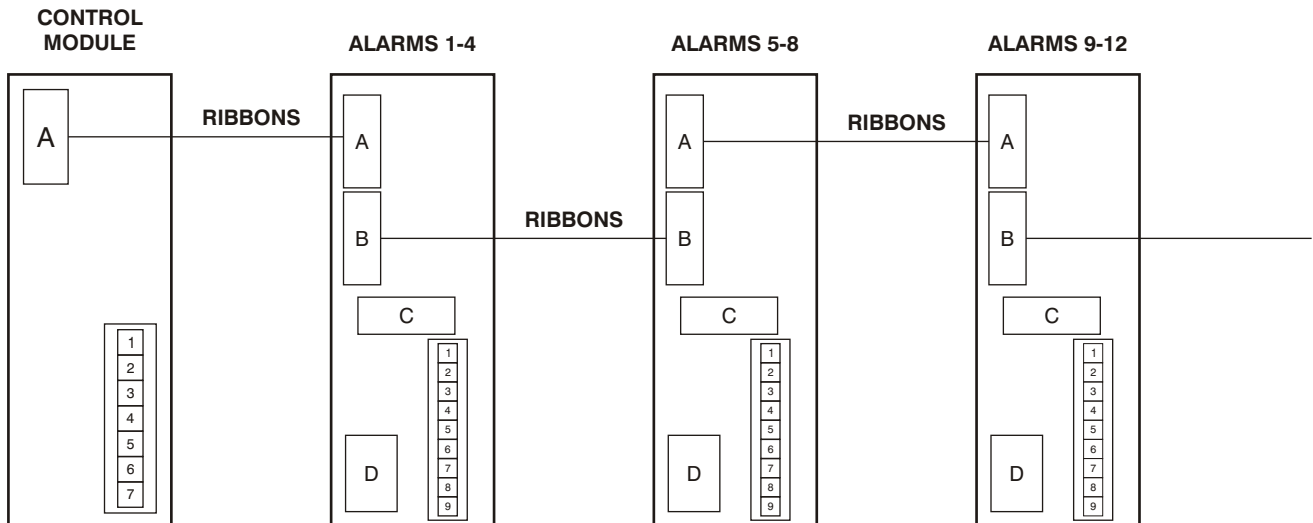

## TYPICAL ALARM MODULE INPUT WIRING

### A - Using internal 24V for Fault Contact Supply

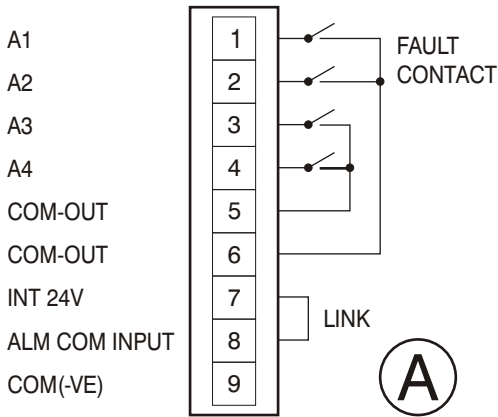

### B & C - Using external PSU for Fault Contact Supply

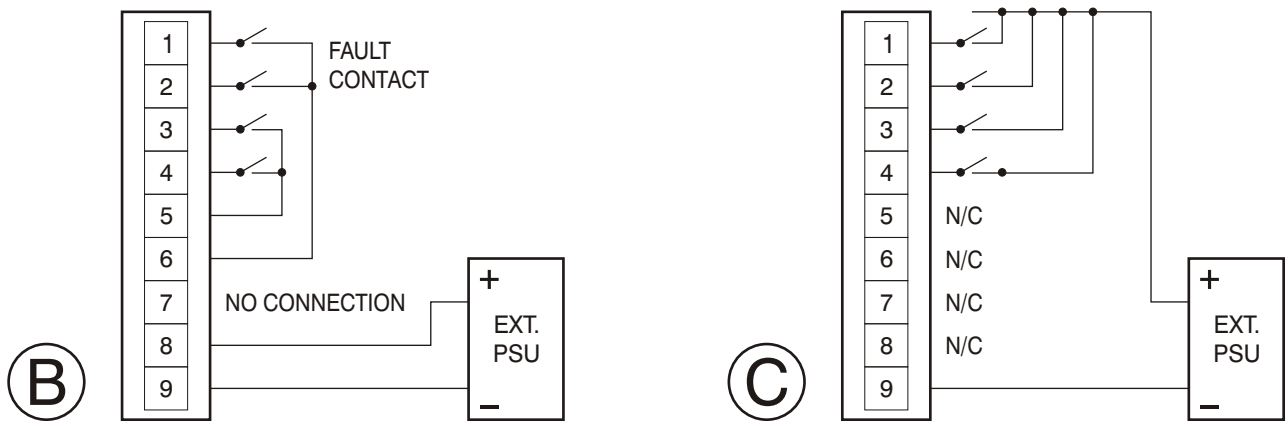

## OPTO COUPLED INPUTS

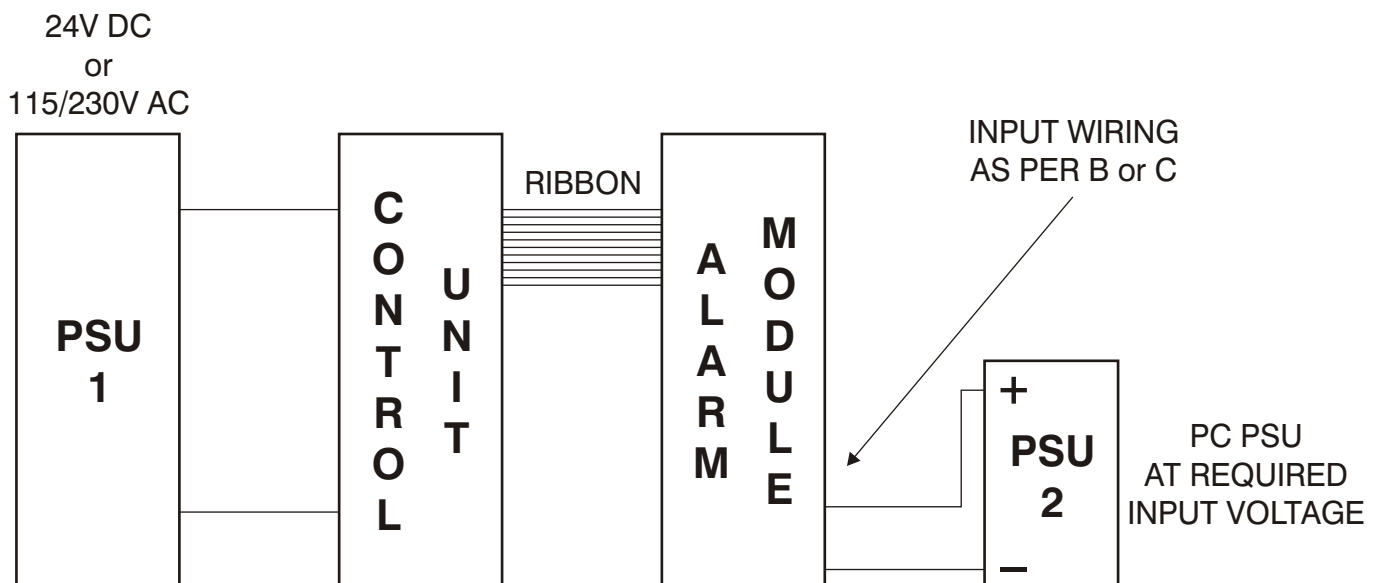

**NOTE:** The outputs of PSU1 and PSU2 should be galvanically isolated from each other

**Specifications:****Power supply:**

Supply voltage	24Vdc $\pm$ 10% or 80V - 260V ac
Slave current consumption	100mA (max) / module @ 24V dc
Master unit current consumption	90mA (max) @ 24V dc

**Alarm inputs:**

Input voltage	Using the internal 24Vdc from the 24Vdc or 80-260Vac master for the field alarms. All inputs are 24V only. If an external power supply is used to supply 24V dc for the master, Fault inputs can be 24V, 32V, 48V, 72V and 110Vdc (special input cards) If requested, opto isolated inputs are also available for the same input voltages but an additional (2nd) isolated DC to DC converter will be necessary if galvanically isolated inputs are required
Input current	7mA @ 24V (max) Opto coupled input option is available for use with two external power supplies.
Fault relays	Optional input "follow me" relays (5A) at input voltage are available

**Relay outputs:**

Horn relay	SPST
Trip output	SPDT
Contact rating	2A @ 250Vac

**SIZES**

All modules have bezel sizes of 48x144. They can be mounted individually (44.5x137mm)

## We appreciate your feedback.

If you have any feedback regarding this product or any of our products or services, please contact us.

**Sales & Technical:**

E-mail: sales@mimic.co.za  
Phone: +27 11 689-5700

**Technical:**

E-mail: edwin@mimic.co.za      don@mimic.co.za  
Mpbile: +27 83 300 5959



ADDRESS: 17 Ramsay Str.  
Booyens 2091  
Johannesburg South Africa

POSTAL: P. O. Box 38493  
Booyens 2016 South Africa  
E-mail : sales@mimic.co.za

TEL: +27 11 689-5700  
FAX: +27 11 493-8821  
WEB PAGE: mimic.co.za